

Torsion Springs—Specification Form

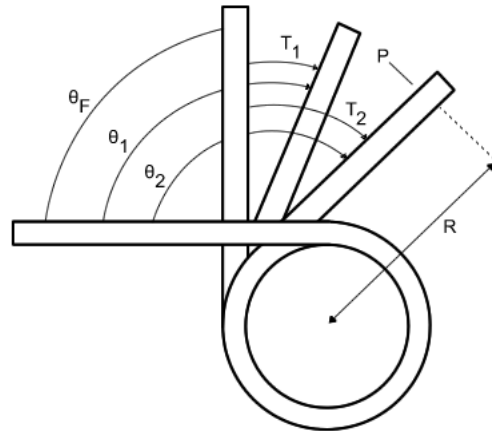
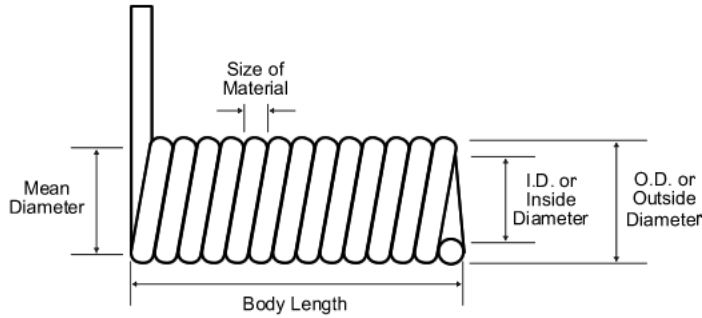

Name _____

Phone Number _____

Mandatory Specifications

(fill in only those required)

1. To work over _____ in. (mm) diameter shaft.
2. OUTSIDE DIAMETER
 - a. _____ in. (mm) max. or
 - b. _____ in. (mm) \pm _____ in. (mm)
3. INSIDE DIAMETER
 - a. _____ in. (mm) min. or
 - b. _____ in. (mm) \pm _____ in. (mm)
4. Length of space available _____ in. (mm)
5. Maximum wound position _____ turns or _____ $^{\circ}$ from free position.
6. Length of moment arm (R) _____ in. (mm)
7. Direction of helix (L, R, or optional) _____
8. Type of ends _____

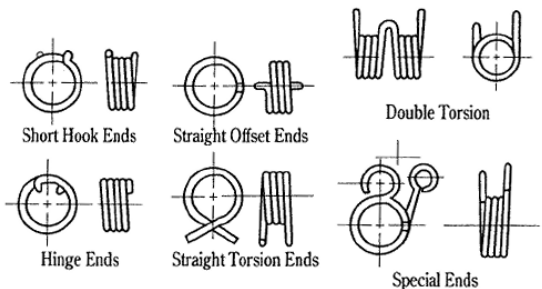

Advisory Data

1. Wire diameter _____ in. (mm)
2. Mean coil diameter _____ in. (mm)
3. Number of coils _____
4. $\theta_F =$ _____ $^{\circ}$ free angle reference

Special Information

1. Type of material _____
2. Finish _____
3. End use or application _____
4. Other _____

Quantity Required: _____

Fill this form out and fax it to us at (780) 461-3460